

AS-250

PSA Oxygen Generator

Specifications

Product Characteristics

Standard Product Flow: 250 SCF/hr¹ (6.57 Nm³/hr²)
Standard Product Pressure: 1–45 psig (5–310 kPa)
Minimum Product Purity: 90%
Product Dew Point: -100°F (-73°C)

Ambient Operating Conditions

Locate the oxygen generator in a well-ventilated area that is protected from weather elements and remains between 40°F (4°C) and 112°F (44°C)

Feed Air Requirements

Average Flow Rate: 48.3 SCFM¹ (1.27 Nm³/min²) Air
Clean and Dry "Plant Air"
Pressure: 90 psig (620 kPa) minimum
Temperature: 122°F (50°C) maximum

Control Power Requirements

120 V ~ ±10%, 50/60 Hz, Single Phase, 1.5 A
220 V ~ ±10%, 50/60 Hz, Single Phase, 0.75 A
Typical Power Consumption (at 90% purity): 180 W

Physical Characteristics

Dimensions (W x D x H): 31 x 28 x 76 in. (79 x 71 x 193 cm)
Weight: 1,034 lb. (469 kg)

Physical Connections

Compressed Air Inlet: 1/2" NPT
Product Gas Outlet: 3/8" NPT/B size oxygen adapter

Certifications and Approvals: NRTL certified compliance to UL 3101.1, CSA, CE Pending

Warranty: 1 Year Parts and Factory Labor*

*An unprotected or inadequately ventilated environment, improper feed air quality, or improper control power may cause damage to the oxygen generator not covered under warranty.

AirSep Corporation continually improves its products and reserves the right to change specifications or design without notice.

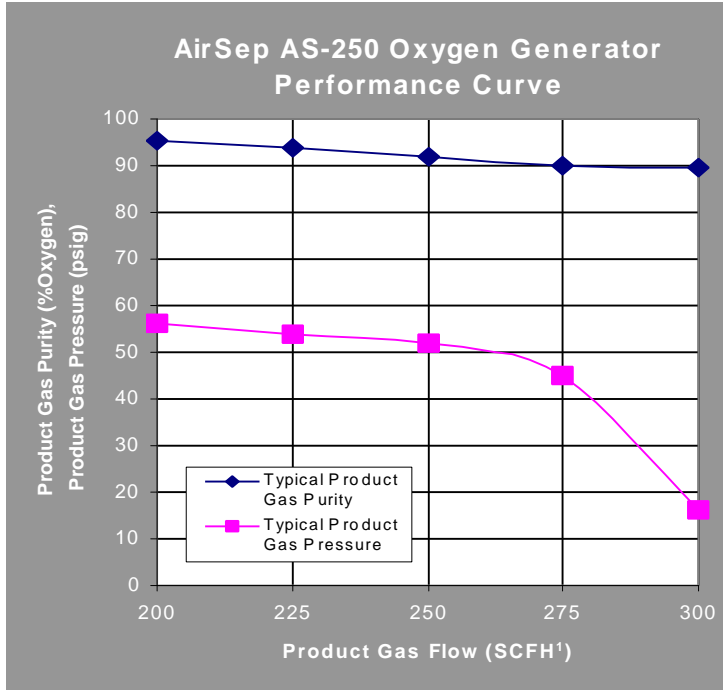

Note: A standard AS-250 delivers 250 SCF/hr¹ (6.57 Nm³/hr²) of 90% minimum purity oxygen at a pressure of 45 psig (310 kPa). If your application requires higher or lower flow and/or pressure, please specify at the time of order.

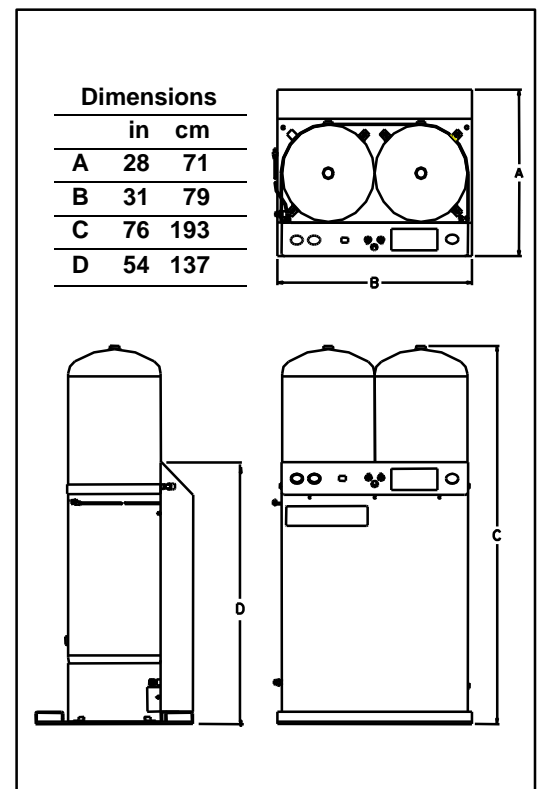

¹ SCF (Standard cubic foot) gas measured at 1 atmosphere and 70°F

² Nm³ (Normal cubic meter) gas measured at 1 atmosphere and 0°C